

TECHNICAL DRAWING

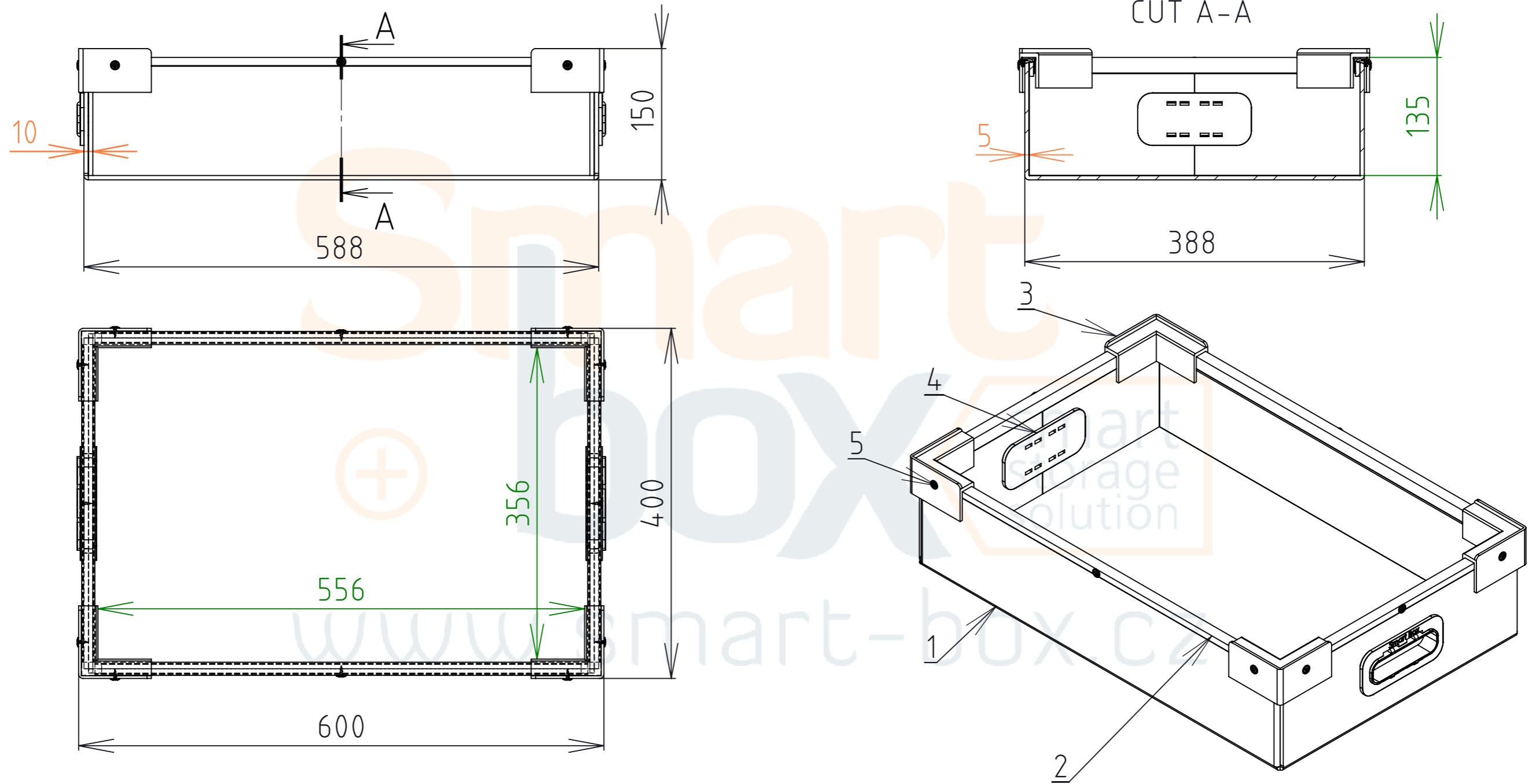

ITEM NO.	DESCRIPTION	QUANTITY	WEIGHT
1	Stacking box-PVC profile-PP corners-02	1	0.61
2	Stacking box-PVC profile-PP corners-U10 Frame-02	1	0.14
3	Stacking PP corner-type1	4	0.05
4	Handle smart - opened x closed	2	0.05
5	Screw-type2-13mm-black	12	0.00

SPECIFICATION	
Weight	1.06 kg
Volume	26.7 l
Scale	1:5